

Dreiphasen-Filterkreisdrosseln

Frequenz 50 Hz
 Nennspannung 400 V
 Kühlungsart AN
 Fußwinkelbefestigung
 Reihenklemmen oder Kabelschuhe
 Isolationsklasse $t_a = 40^\circ\text{C}/\text{B}$
 Schutzklasse I
 Schutzart IP00

FKD

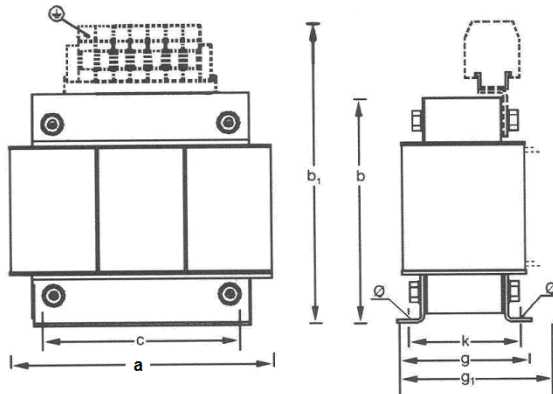

Kerntyp Maße

	a	b	b1	c	g	g1	k	ø
3UI75/41,5	150	138	202	113	82	-	65	5,8x11
3UI90/31,5	180	164	228	136	76	-	57	7x13
3UI90/51,5	180	164	228	136	96	-	77	7x13
3UI114/40	228	204	274	176	90	-	71	7x13
3UI114/64	228	204	274	176	114	155	95	7x13
3UI120/61	240	214	284	185	111	155	91	9x13
3UI120/71	240	214	284	185	121	175	101	9x13
3UI132/46	264	235	-	200	106	145	76	10x18
3UI132/60	264	235	-	200	120	170	90	10x18
3UI132/72	264	235	-	200	132	180	102	10x18
3UI150/52	300	275	-	224	122	175	94	10x18
3UI150/65	300	275	-	224	135	190	107	10x18
3UI150/77	300	275	-	224	147	200	119	10x18